

# 835PB 1.4" exit HF driver



## SPECIFICATIONS

Nominal exit diameter	1.4"/35.6 mm
Rated impedance	8/16 $\Omega$
Power handling <sup>1</sup>	100 W
Continuous program power <sup>2</sup>	200 W
Sensitivity <sup>3</sup>	110.5 dB
Rated frequency range <sup>4</sup>	500 Hz – 20kHz
Recommended min. XO frequency <sup>4</sup>	800 Hz
Re	6.2/12.4 $\Omega$
Minimum impedance	7.8/ 14.5 $\Omega$
Diaphragm material	structural aluminum alloy
Voice coil diameter	76.2 mm (3")
Voice coil winding	edge-wound ribbon
Voice coil wire	copper-clad aluminum
Voice coil former	high temperature polyimide
Magnet	ferrite ring
Exit angle <sup>5</sup>	4.8°

## Mounting and mechanical parameters

Mounting	4 x M6 on $\varnothing$ 101.6mm (4 in)
Overall diameter	190.5 mm (7.5 in)
Overall depth	71.9 mm (2.83 in)
Net weight	6.63 kg (14.6 lbs.)

## Optional accessories

Replacement diaphragm assembly	1750PB-8/16– binding posts
--------------------------------	----------------------------

- Distinguished by transparent, high resolution sound and minimum distortion
- designed to withstand long term high stress operation with high peak factor
- ideal for touring sound, stage monitors, high performance installed and portable sound systems
- proprietary aerospace grade aluminum alloy diaphragm with highest tensile strength to weight ratio guarantees long term fatigue resistance, extended HF and accurate signal peak reproduction
- diaphragm assembly construction with optimized damping eliminates ringing typical for other metal domes
- heat stabilized polymer surround ensures low distortion at high SPL and long term performance stability
- high performance 76.3mm (3") edge-wound ribbon wire voice coil with advanced adhesives for maximum reliability
- 200 W continuous program power
- self-aligning diaphragm assembly facilitates service in the field

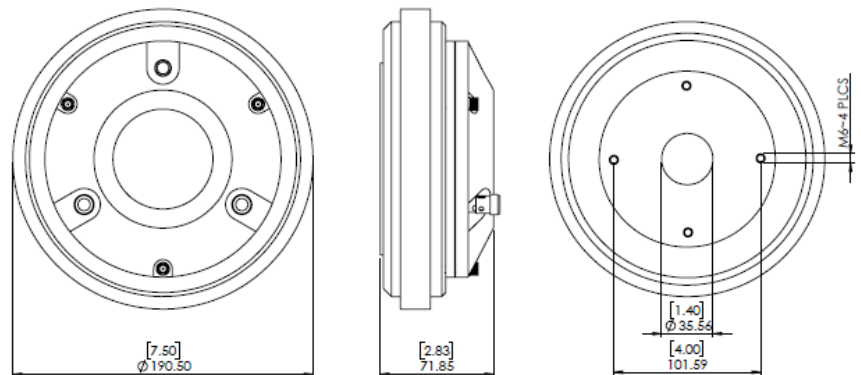

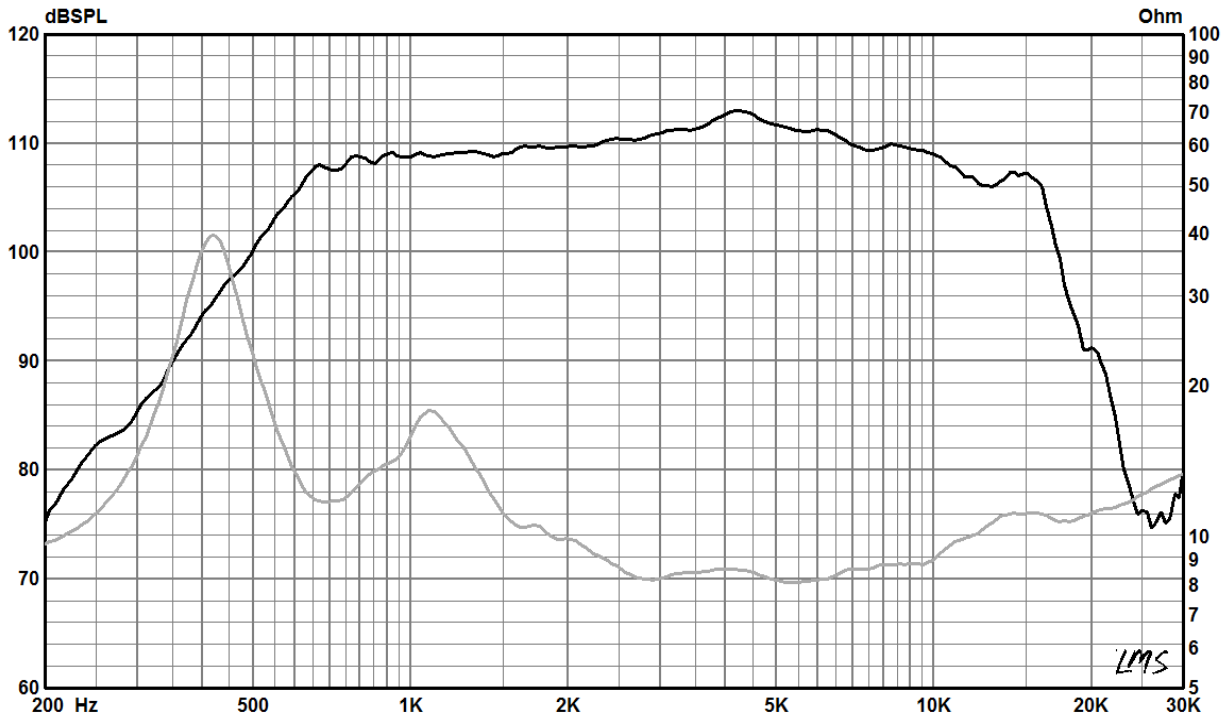

Frequency response and impedance of 835PB-8 on specified horn, free field <sup>3</sup>.

## Specifications notes

1. AES2-1984 Rev.2003. Tested using XO with 24dB/oct. slope @ 1.2 kHz.
2. Continuous program power is defined at 3dB higher than AES power and reflects power handling capacity for typical music and cinema content reproduction.
3. Driver mounted on horn with 120°x40° nominal coverage and following dimensions: 356 mm (14") mouth width, 152mm (6") mouth height, 165mm (6.5") horn depth. Measured at 1W/1m in simulated free field conditions as per AES 2-2012 and IEC 60268-5 (Ed.3.1 2007-09). Sensitivity is calculated based on SPL frequency response at 1W/1m, averaged in 800 Hz – 5 kHz band.
4. Specified in accordance with IEC 60268-5 (Ed. 3.1 2007-09). Defines lowest recommended operating frequency band for typical application with 24 dB/Oct. high pass filter. If lower filter slope rate is used, a higher XO point is recommended. Higher XO frequency is recommended, if higher max SPL is required.
5. Total flare angle of conical exit. The angle should be considered for proper coupling with a waveguide/horn. The waveguide/horn throat expansion angle and shape should provide smooth continuity of mated surfaces for best results. The driver exit angle and its integration with a horn will also affect dispersion at very high frequencies.